

7512-62

120 liter XXL Nestable drum



Product part	Product code	Materials
Drum	7512	HDPE
Lid	7502	HDPE
Gasket	H14	EPDM

Capacity	Liters	US Gallons
Brimful	136	35.93
When closed	126	33.29

Hazardous material information	
Hazardous material type	Solids
Packaging group	I – II – III
UN marking	1H2/X100/Y150/Z150/S/--/NL/CURTEC 170612
Maximum gross mass (kg)	X=100 Y=150 Z=150

Weight	Grams	Ounces
Drum	4260	150.27
Lid	1985	70.02
Gasket	212	7.48
Total	6457	227.77

Weight tolerance
All products have a tolerance of $\pm 4\%$ of the initial weight mentioned on this data sheet

Dimensional tolerances	%
Height	± 2.5
Diameter	± 1.5

Wall thickness	mm
Minimal wall thickness	≥ 2.2
Nominal wall thickness	≥ 2.7

Colors	Color code	PMS references
Drum*	White 004	/
Lid*	Blue 625	2728 C

* Other colors available on request

Product identification	Drum	Lid
Manufacturer ID	Bottom	--
Product code	Bottom	--
Recycle logo / Material type	Bottom	Inside
Date clock	Bottom	Inside
UN-mark	Side wall	--
Food logo	Bottom	--
Material track clock	Bottom	--
CFR49-mark	Bottom	--

Other information
Maximum filling temperature is 70°C/ 158°F
Contents must have cooled to 30°C/ 86°F before containers can be closed and stacked
DoC available on request
UN certificate available on request
MVTR declaration available on request
User manual available on request
All drums can be made tamper evident with application of compact seal # 7800

DISCLAIMER

CurTec manufactures packaging material for a wide range of purposes. This declaration is restricted to the packaging material as it leaves the production facility. CurTec has neither control over final end use of the product nor over processing conditions. It is therefore the responsibility of the end user to check compliance with the relevant regulations and to validate material performance in the end application through proper end use testing.

© 2020 Property of CurTec International B.V. All rights explicitly reserved, it is not allowed to copy or communicate to other parties without written consent of CurTec.

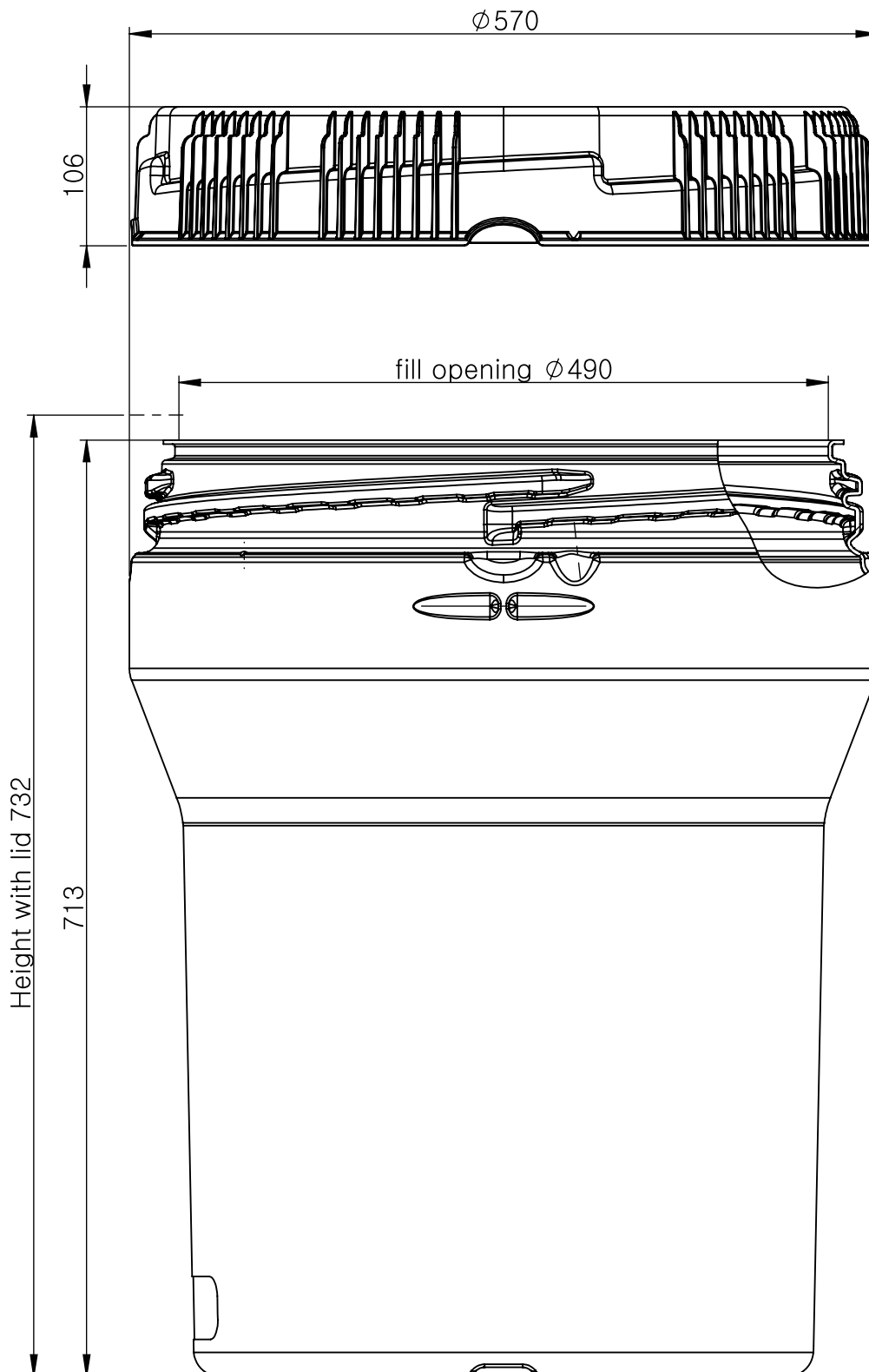

Title 7512 XXL Nestable drum 120 liter

Revision	Rev. Date	Units
0	12-12-2019	mm



This document is property of CurTec Nederland B.V.
and may not be copied or communicated without written consent.
All Rights Reserved

